



# HDFL

Explosion-proof LED Flood Light/High-bay Lighting for Hazardous Environments

Efficient lighting solutions designed for rugged and demanding spaces

12,800 TO 32,000 LUMENS



## ABOUT US

- Trusted provider of robust LED lighting engineered for the most challenging industrial settings
- Supporting clients across industries like oil & gas, mining, manufacturing, and marine sectors.
- Committed to excellence, reliability, and adherence to the highest safety standards.

---

## WHY CHOOSE HAZBRITE

### ⇒ SAFETY YOU CAN COUNT ON :

- Thoroughly tested by experts to meet stringent safety requirements.
- Compliant with industry-leading certifications and protocols.
- Built to deliver long-lasting performance in demanding condition.

### ⇒ FAST AND RELIABLE DELIVERY OF PRODUCTS :

- Majority of orders fulfilled on time delivery.
- Immediate availability of products for urgent needs.
- Real-time tracking for complete visibility and control.

### ⇒ EXPERTISE DRIVEN SERVICES :

- Dedicated support team with deep industry knowledge.
- Customized lighting solutions tailored to your project's need.
- Comprehensive after-sales support and maintenance.

### ⇒ ECO - CONSCIOUS SOLUTIONS ;

- High-efficiency lighting that cuts energy usage.
- Environmentally responsible design and packaging.
- Sustainable products that reduce waste and operational costs.

---

**SETTING THE STANDARD IN SAFETY-ORIENTED  
LIGHTING FOR CRITICAL, HAZARDOUS & SAFE  
OPERATIONS ALIKE.**

## RATINGS AND CERTIFICATIONS

### NEC/CEC STANDARD

#### UL 844 Hazardous Locations

- Class I Division 1, Groups C, D
- Class I Division 2, Groups A, B, C, D
- Class II Division 1, Groups E, F, G
- Class II Division 2, Groups F, G
- Class III
- Class I, Zone 1, Group IIB
- Class I, Zone 2, Group IIC



CSA C22.2 No.

CSA C22.2 No.

UL 1598 Wet Locations

UL 1598A Marine Outside Type (Salt Water)

UL 8750 LED Safety

Paint Spray Booth

ABS, FCC

IP66/67

IK09

5G

NEMA 4X

**5-year product warranty**

**Lumen Maintenance: L70 > 150,000 hours @ 25°C**



## STANDARD MATERIALS

- Lamp housing, Splice box, and adapter – die cast copper-free aluminum
- Finish – baked Powder epoxy/polyester
- Lens – heat, shock and impact resistant clear or diffuse glass lens
- Gaskets – high temperature resistant silicone
- Hardware – stainless steel
- Lacquer-free nameplate

*Note : Product Specifications and Design subject to change without notice*

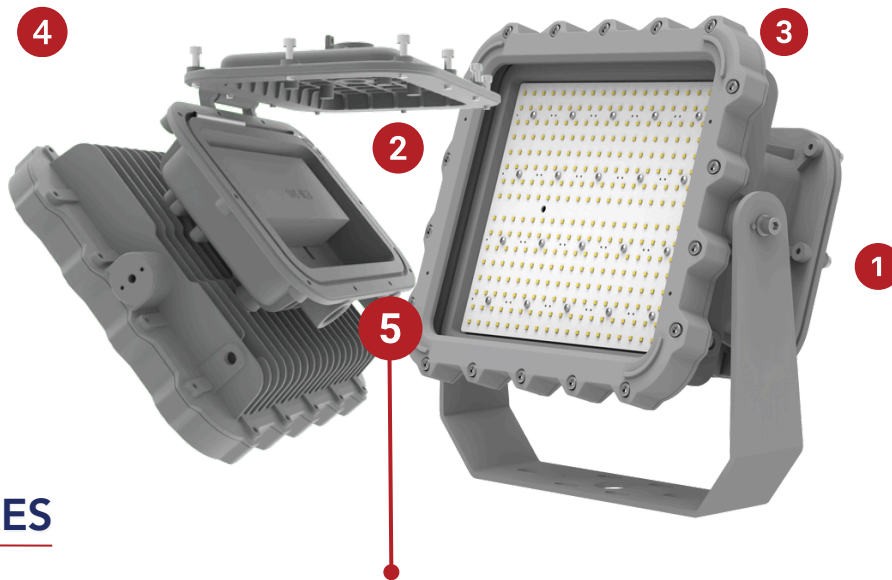

## KEY FEATURES

1. Lightweight design weighing just 11.5 kg, offering optimal balance of weight, safety, and long-lasting durability.
2. Innovative hinge mechanism for effortless and secure installation.
3. High-efficiency LEDs delivering up to 160 lm/W, ensuring consistent brightness while reducing energy consumption compared to traditional lighting solutions.
4. Multiple beam angles tailored to meet the demands of diverse applications and environments.
5. 360° adjustable corrosion-, vibration-, impact-, and shock-resistant U-bracket, validated by 5G, 3-axis vibration testing for exceptional reliability.
6. Universal mounting accessories designed for seamless retrofitting and adaptability.

## ADDITIONAL FEATURES

- Universal Voltage: 120-277V/AC (50/60Hz)
- High efficacy up to 170lm/W
- 7 different optics: 30° / 60° / 90° / 110° / T2 / T3 / T4
- CCT Adjustable (3000K/ 4000K /5000K)
- Wildlife Friendly Amber color options
- 10kV surge protector is standard, 20kV is optional
- Dimming: Standard 1 – 10VDC
- Ambient temperatures -40°C to +65°C
- Resistant up to 2,000 PSI of hose directed water
- Tested 1000hrs salt spray to standard ASTM“B117-11”
- Harsh & Hazardous Duty



## APPLICATIONS



Chemical



Oil and Gas

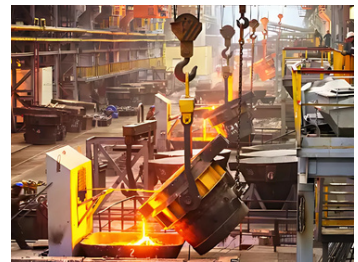

Foundries



Pulp & Paper



Power Generation



Waste & Sewage  
Treatment



Land Rigs



Offshore Rigs



Manufacturing

## TECHNICAL DATA

### ELECTRICAL DATA

Rated Power	80W / 100W / 150W / 200W
Input Voltage	100-277, 347-480V/AC
Input Frequency	50/60Hz
Power Factor	> 0.95
Driver Efficiency	≥ 90%
DC output Ripple & Noise	< 200mVP-P

### OPTICAL DATA

Lumen Output	12800 lumens = 32000 lumens
Luminous Efficacy (Lumens per Watt)	160 - 170 lumens/W
Beam Angle	30° / 60° / 90° / 110° / T2 / T3 / T4
Correlated Color Temperature (CCT)	Amber 2700K 3000K 4000K 5000K
CRI	Ra>70

### ENVIRONMENTAL DATA

Ambient Operating Temperature	-40°C~+65°C (80W 100W 150W ) -40°C~+60°C (200W )
Ambient Operating Humidity	10%~90% RH
Atmospheric Pressure	86~106KPa

### TECHNICAL DATA

Lens Material	Tempered Glass
Mounting Options	Pendant / Ceiling / Wall Mount / Stanchion/ U-bracet
Cable Entries	3/4" NPT, 1-1/4" NPT, 1-1/2" NPT
Net Weight	11.5kg ( 25.35 lbs )

## ORDERING INFORMATION

# HDFL 24-U-1-30 - NW- TG - PD- GR - XX

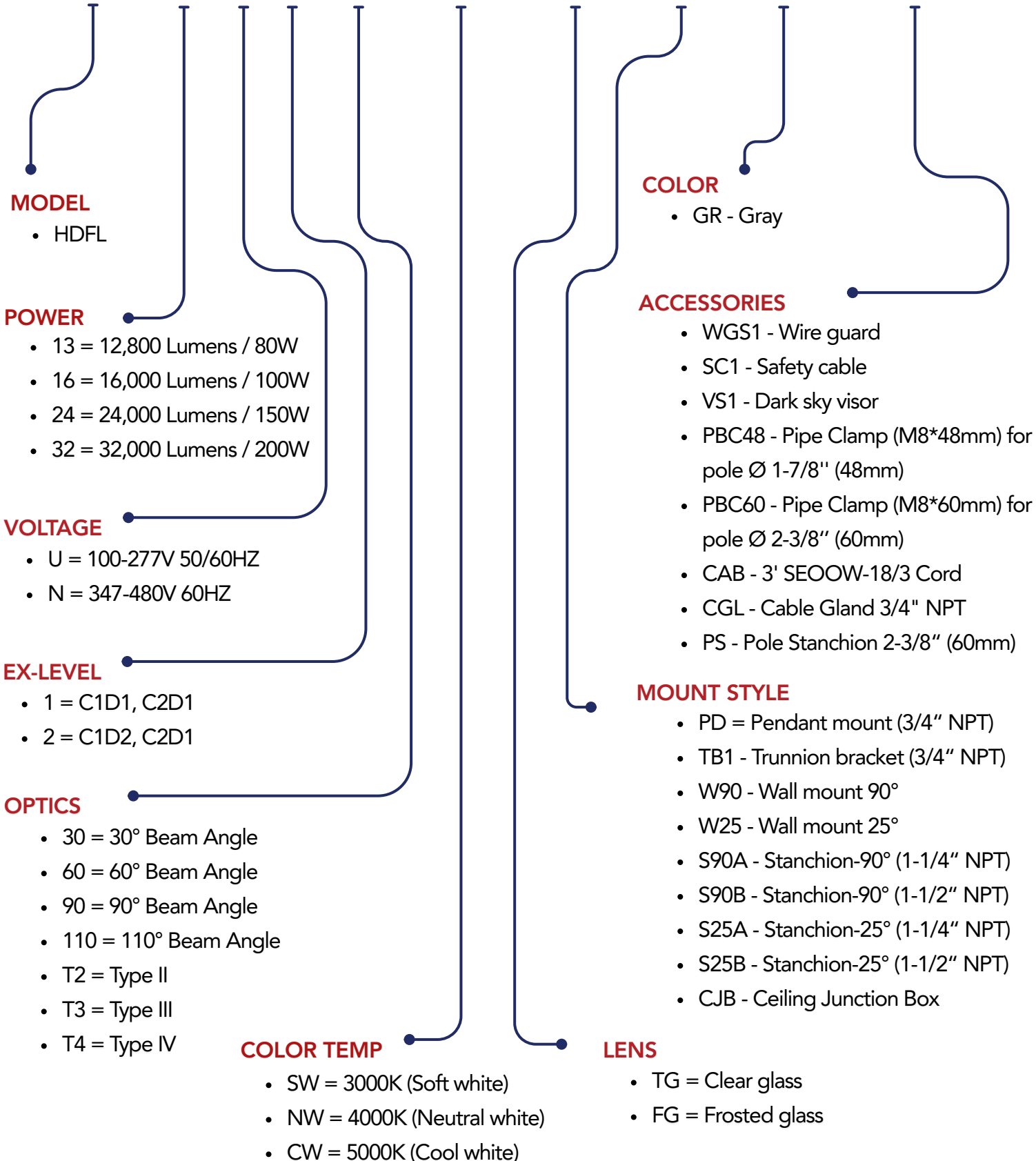

Note : Surge Protector is already included.

## MOUNTING OPTIONS

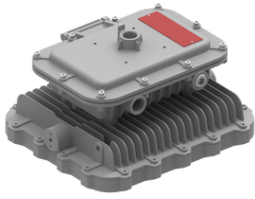

**PD (Standard)**  
Pendant Mount  
3/4" NPT

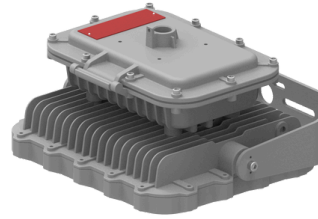

**TB1**  
Trunion Bracket  
3/4" NPT

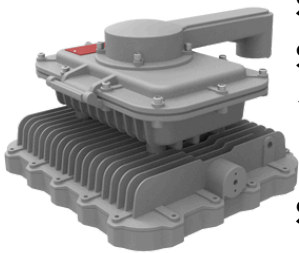

**S90A**  
Stanchion mount 90°  
1-1/4" NPT

**S90B**  
Stanchion mount 90°  
1-1/2" NPT

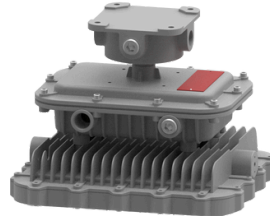

**CJB**  
Junction Box  
3/4" NPT

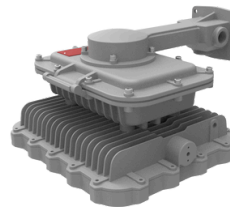

**W90**  
Wall mount 90°  
3/4" NPT

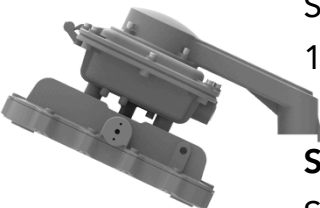

**S25A**  
Stanchion mount 25°  
1-1/4" NPT

**S25B**  
Stanchion mount 25°  
1-1/2" NPT

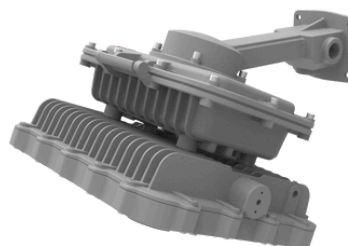

**W25**  
Wall mount 25°  
3/4" NPT

## ACCESSORIES

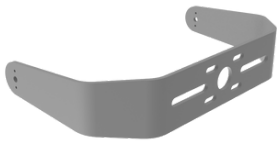

**TB1**

Trunnion Bracket  
3/4" NPT

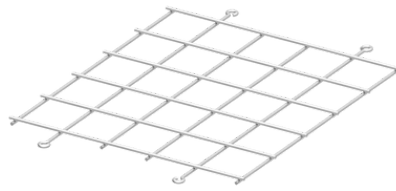

**WGS1**

Stainless Steel  
wire guard



**SC1**

Stainless Steel  
safety cable (4mm)



**PBC60**

Pipe Clamp (M8\*60mm)  
for pole Ø 2-3/8"



**PBC48**

Pipe Clamp (M8\*48mm)  
for pole Ø 1-7/8"



**CAB**

3' SEOOW-18/3 Cord  
(Factory Installed)  
Applicable to C1D2

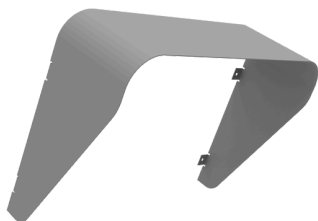

**VS1**

Stainless Steel  
dark sky visor



**CGL**

Cable Gland  
3/4" NPT  
Suitable for C1D2

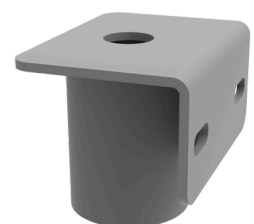

**PS**

Pole Stanchion  
2-3/8" (60mm)

*Note : SP10 is already included.*

## BEAM DISTRIBUTION DATA

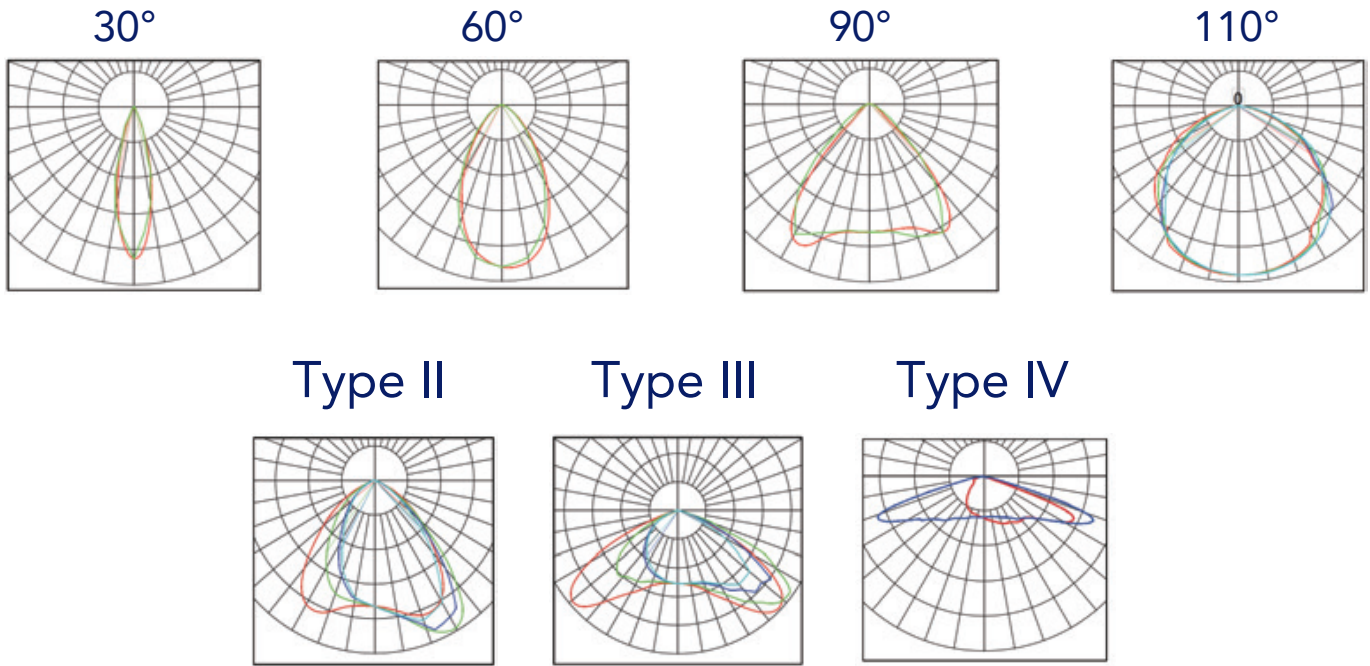

## DIMENSIONS

UNIT: MM(IN)

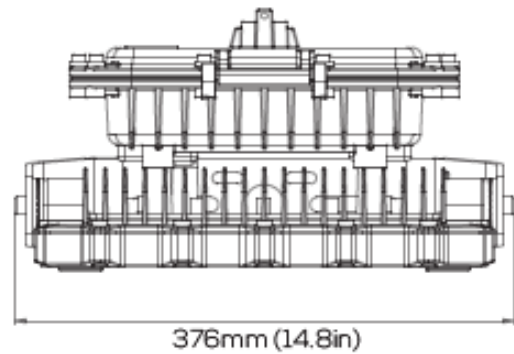
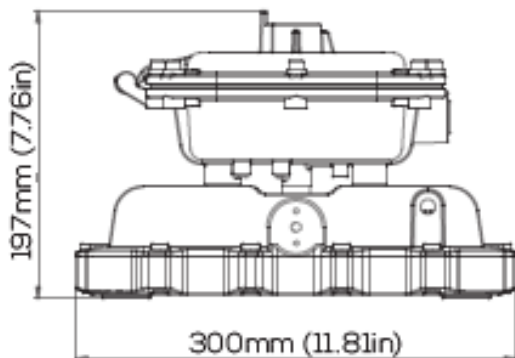
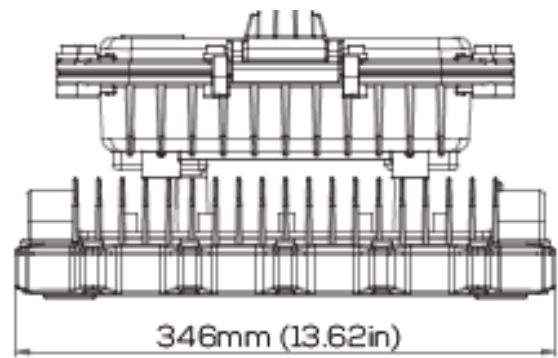
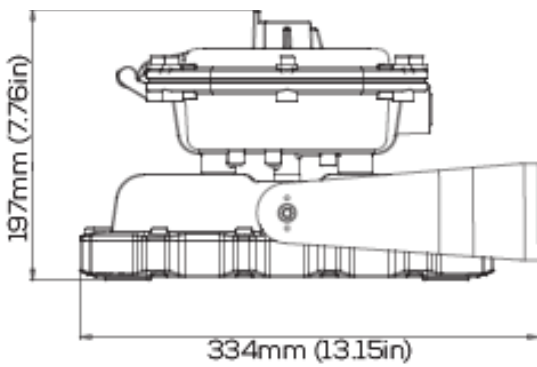

# LIGHTING BASICS FOR HAZARDOUS LOCATIONS

## CLASSIFICATION OF DIVISIONS AND ZONES

Hazard Level	Division Scheme	Zone Scheme	Definitions
Continuous Hazard	Division 1	Zone 0 / Zone 20	A place in which an explosive atmosphere is continually present
Intermittent Hazard		Zone 1 / Zone 21	A place in which an explosive atmosphere is likely to occur in normal operation
Hazard Under Abnormal Conditions	Division 2	Zone 2 / Zone 22	A place in which an explosive atmosphere is not likely to occur in normal operation, but may occur for short periods

## IP CODES

Solid Objects	Liquids
0 - No protection	0 - No Special protection
1 - Objects > 50mm diameter	1 - Vertically dripping Water
2 - Objects > 12.5mm diameter	2 - Vertically dripping water when enclosure tilted by 15°
3 - Objects > 2.5mm diameter	3 - Sprayed water up to 60°
4 - Objects > 1.0mm diameter	4 - Sprayed water from all directions
5 - Dust protected	5 - Water Jets
6 - Dust Tight	6 - Powerful water jets
	7 - Temporary submersion to a depth of 1m
	8 - Extended submersion to a depth of >1m

## LIGHTING BASICS FOR HAZARDOUS LOCATIONS

### HAZARDOUS ATMOSPHERE CATEGORY

Explosive Atmosphere	Typical Hazard Material	Hazard Class	Division Group	NEC 505 / CEC 18
Gases, vapors, and liquids	A: Acetylene B: Hydrogen, etc. C: Ether, etc. D: Hydrocarbons, fuels, solvents, etc.	Class I	Group A Group B Group C Group D	IIC IIC or IIB+H2 IIB IIA
Dusts	E: Metal dusts (conductive and explosive) F: Carbon dusts (some are conductive, and all are explosive) G: Flour, starch, grain, combustible plastic or chemical dust (explosive)	Class II	Group E Group F Group G	IIIC IIIC IIIB
Fibers and flyings	Textiles, wood-working, etc. (easily ignitable, but not likely to be explosive)	Class III	Not Applicable	IIIA

### IK CODES

IK CODE	IK01	IK02	IK03	IK04	IK05	IK06	IK07	IK08	IK09	IK10	IK11
IMPACT ENERGY J	0.14	0.2	0.35	0.5	0.7	1	2	5	10	20	50

# LIGHTING BASICS FOR HAZARDOUS LOCATIONS

## TEMPERATURE CLASSIFICATION

MARKING	NEC 500 / CEC	NEC 505 / IEC GROUP II
450°C	T1	T1
300°C	T2	T2
280°C	T2A	
260°C	T2B	
230°C	T2C	
215°C	T2D	
200°C	T3	T3
180°C	T3A	
165°C	T3B	
160°C	T3C	
135°C	T4	T4
120°C	T4A	
100°C	T5	T5
85°C	T6	T6

## LIGHTING BASICS FOR HAZARDOUS LOCATIONS

### ZONE CLASSIFICATION AND EQUIPMENT PROTECTION LEVEL (EPL)

GAS ZONES	DEFINITION	ATEX CATEGORY	EPL	REQUIRED PROTECTION
Methane	Mines with methane and dust. Equipment remains energised in explosive atmosphere	M1	Ma	Two Faults
Methane	Mines with methane and dust. Equipment is de-energised in explosive atmosphere	M2	Mb	Severe Normal Operation
Zone 0	Explosive atmosphere present continuously or for long periods, frequently	1G	Ga	Two Faults
Zone 1	Explosive atmosphere is likely to occur under normal conditions, occasionally	2G	Gb	One Fault
Zone 2	Explosive atmosphere is unlikely to occur under normal conditions, short periods	3G	Gc	Normal Operation
DUST ZONES	DEFINITION	ATEX CATEGORY	EPL	REQUIRED PROTECTION
Zone 20	Explosive atmosphere present continuously or for long periods, frequently	1D	Da	Two Faults
Zone 21	Explosive atmosphere is likely to occur under normal conditions, occasionally	2D	Db	One Fault
Zone 22	Explosive atmosphere is unlikely to occur under normal conditions, short periods	3D	Dc	Normal Operation

CONTACT THE HAZBRITE TEAM FOR MORE ENQUIRIES.

**HAZBRITE**

www.hazbrite.com  
sales@hazbrite.com  
+85238533890

Unit 2A, 17/F, Glenealy Tower,  
No. 1 Glenealy, Central,  
Hong Kong.



## Disclaimer

The information provided is accurate to the best of Hazbrite's knowledge at the time of publication. However, customers and end-users should consult the latest product specifications, installation guides, terms, and warranties available at [www.hazbrite.com](http://www.hazbrite.com), which shall take precedence in case of any discrepancies or conflicts.